

# Activity 1.5 Investigating arteries and veins

## Purpose

- To relate the structures of blood vessels to their functions.
- To practise some experimental skills, including identification of variables, producing valid results, presenting data, drawing conclusions and considering safety.

## Safety

*Wear eye protection while stretching blood vessels.*



*Benches should be thoroughly cleaned with 1% Virkon or other suitable disinfectant.*



*Wash your hands after handling tissue once cleaning up is finished.*

## You need

- Ring of artery and vein
- Mass carrier
- 5 × 10 g masses
- Hook
- Clamp stand, boss and clamp
- Metre rule
- Graph paper
- Prepared slide of artery and vein T.S.
- Prepared slide of lung or thyroid gland T.S. to show capillaries
- Microscope
- Histology book for microscope images and notes
- Drawing paper

## Procedure

### Part A: Elastic recoil in arteries and veins

- 1 Suspend a ring of artery from a hook on a clamp stand. Use a metre rule to record the length of the ring once the mass carrier has been attached to the free end of the ring.
- 2 Attach a 10 g mass (see Figure 1) and record the length of the ring after the mass is added.
- 3 Remove the mass and record the length of the ring.
- 4 Repeat steps 2 and 3 using 20, 30, 40 and 50 g masses. Record the length with and without the masses each time.

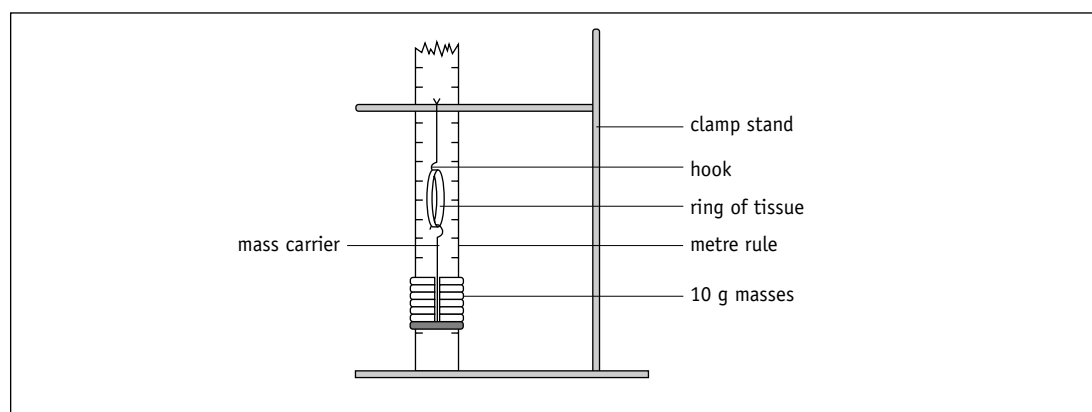

**Figure 1** Measuring the length of the ring.

- 5 Calculate % change in length:

$$\% \text{ change in length} = \frac{(\text{new length} - \text{original length})}{\text{original length}} \times 100$$

## Activity 1.5 Investigating arteries and veins

## Student

- 6 Enter your results into an appropriate table. Remember that a good table of results should have:
- an informative title
  - the first column containing the independent variable (the factor that is varied by the experimenter; in this experiment it is the mass)
  - the second and subsequent columns containing the dependent variables (The value of the dependent variable *depends* on the value of the independent variable. In this case the length of the ring depends on how much mass is added, so ring length is the dependent variable.)
  - informative column headings; each column should have a descriptive heading
  - units in the heading, not next to the numerical data

Additional columns can be added to include calculations based on raw data such as % change in length, etc.

- 7 Plot two appropriate graphs, one for artery, one for vein. Remember that the most appropriate type of graph should be chosen to represent data, e.g. bar chart, pie chart, histogram or line graph.

A **bar chart** is used when the independent variable is non-numerical or discontinuous, e.g. the different stages of mitosis.

A **pie chart** can be used to display data that are proportions or percentages.

A **histogram** is used when the independent variable is numerical and the data are continuous, but classified into groups, e.g. number of leaves of different lengths.

A **line graph** can be used to show relationships in data which are not immediately obvious from tables. Both the dependent and independent variables are continuous. The independent variable normally goes on the *x*-axis.

Remember to include:

- an informative title
- sensible scales on each axis, if appropriate
- labels on both axes
- units on both axes, if appropriate
- a key.

(For more detail on presenting data see Alan Cadogan (ed.) (2000) *Biological Nomenclature: Standard terms and expressions used in the teaching of biology*, 3rd Edition, Institute of Biology ISBN 0900490365)

In this experiment plot % change in length against mass.

Values for adding and removing masses should be plotted on the same graph. (You could colour-code the points to show which are adding and which removing masses.)

### Part B: Histology of blood vessels

- 8 Examine slides of artery and vein. Identify the three main regions of the vessel wall, and the tissues in these regions:
- a) external, middle and inner layers of tissue
  - b) elastic and collagen fibres
  - c) smooth muscle.
- 9 Sketch a plan of a cross-section across both vessels to show the amount and distribution of each type of tissue.
- 10 Annotate the sketch with notes on the three regions and other features of the vessel, e.g. thickness of wall, tissues in the three regions.
- 11 Using H.P. (high power) examine a capillary in a section of an organ, e.g. lung or thyroid.

## Activity 1.5 Investigating arteries and veins

### Questions

- Q1** How do the results for artery and vein compare when looking at:
- % change in length on loading?
  - return to the original length on unloading?
- Q2** What are the main properties of:
- elastic fibres
  - collagen?
- Q3** Explain any trends or patterns in the data, supporting your ideas with evidence from the data and your biological knowledge of the histology of arteries and veins.
- Q4** Explain how the properties of arteries and veins that you have investigated link to the functions of arteries and veins in the body.
- Q5** State two ways in which the structure of a capillary is related to its function.
- Q6** What is the role of smooth muscle in blood vessel walls?
- Q7** Comment on any safety issues that should be considered when performing this experiment.
- Q8** Suggest variables that should ideally be controlled in this experiment.

Remember that the *independent variable* is the factor that you vary. You may be able to choose the range of values of the independent variable. The dependent variable *depends* on the value of the independent variable. Any other variables that may affect the dependent variable should be controlled (kept constant) where possible, in order to produce results that are reliable.

**Q9** Suggest modifications to the experimental procedure that would ensure that more reliable and valid results are produced. Remember that reliable and valid results are produced through precise, repeatable measurements made with apparatus and experimental procedures that are suitable for the task.

**Reliability** means that the same results are recorded if the activity is repeated. This partly depends on the number of measurements or observations that were taken. Ideally, a large number of replicates (repeat measurements) should be taken, and any readings that vary considerably from the others should be repeated or discounted. A mean or some other average (e.g. a median) can be calculated to be representative of the set of results. The pressure of time usually puts a limit on the number of replicates that can be taken.

**Validity** means that the experimenter succeeds in measuring what he or she intended to, in other words that there is little or no difference between the actual values and the recorded values.

**Precision** is the closeness of repeated measurements to each other. Precision involves the choice of apparatus and the skill with which it is used. Precise readings are not necessarily accurate. A faulty piece of equipment or an incorrectly used piece of apparatus may give very precise readings (repeated values close together) but inaccurate (not valid) results. To be accurate, a measurement should be close to the true value.